

# Semiconductor Electronics : Materials, Devices and Simple Circuits

## 14.1 Introduction

- When using a triode, as an amplifier, the electrons are emitted by
  - grid and collected by cathode only
  - cathode and collected by the anode only
  - anode and collected by cathode only
  - anode and collected by the grid and by cathode. (1996)
- For amplification by a triode, the signal to be amplified is given to
  - the cathode
  - the grid
  - the glass envelope
  - the anode (1992)
- For an electronic valve, the plate current  $I$  and plate voltage  $V$  in the space charge limited region are related as
  - $I$  is proportional to  $V^{3/2}$
  - $I$  is proportional to  $V^{2/3}$
  - $I$  is proportional to  $V$
  - $I$  is proportional to  $V^2$  (1992)
- When a triode is used as an amplifier the phase difference between the input signal voltage and the output is
  - 0
  - $\pi$
  - $\pi/2$
  - $\pi/4$ . (1990)

## 14.2 Classification of Metals, Conductors and Semiconductors

- Choose the only false statement from the following.
  - In conductors the valence and conduction bands overlap.
  - Substances with energy gap of the order of 10 eV are insulators.
  - The resistivity of a semiconductor increases with increase in temperature.
  - The conductivity of a semiconductor increases with increase in temperature. (2005)
- Carbon, silicon and germanium atoms have four valence electrons each. Their valence and

conduction bands are separated by energy band gaps represented by  $(E_g)_C$ ,  $(E_g)_{Si}$  and  $(E_g)_{Ge}$  respectively. Which one of the following relationships is true in their case?

- $(E_g)_C > (E_g)_{Si}$
  - $(E_g)_C < (E_g)_{Si}$
  - $(E_g)_C = (E_g)_{Si}$
  - $(E_g)_C < (E_g)_{Ge}$  (2005)
- In semiconductors at a room temperature
    - the valence band is partially empty and the conduction band is partially filled
    - the valence band is completely filled and the conduction band is partially filled
    - the valence band is completely filled
    - the conduction band is completely empty. (2004)

## 14.3 Intrinsic Semiconductor

- C and Si both have same lattice structure; having 4 bonding electrons in each. However, C is insulator whereas Si is intrinsic semiconductor. This is because
  - in case of C the valence band is not completely filled at absolute zero temperature
  - in case of C the conduction band is partly filled even at absolute zero temperature
  - the four bonding electrons in the case of C lie in the second orbit, whereas in the case of Si they lie in the third
  - the four bonding electrons in the case of C lie in the third orbit, whereas for Si they lie in the fourth orbit. (2012)
- At absolute zero, Si acts as
  - non metal
  - metal
  - insulator
  - none of these. (1988)

## 14.4 Extrinsic Semiconductor

- For a  $p$ -type semiconductor, which of the following statements is true?
  - Electrons are the majority carriers and pentavalent atoms are the dopants.

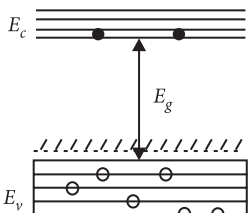
- (b) Electrons are the majority carriers and trivalent atoms are the dopants.  
 (c) Holes are the majority carriers and trivalent atoms are the dopants.  
 (d) Holes are the majority carriers and pentavalent atoms are the dopants. (NEET 2019)
11. In a  $n$ -type semiconductor, which of the following statement is true?  
 (a) Holes are minority carriers and pentavalent atoms are dopants.  
 (b) Holes are majority carriers and trivalent atoms are dopants.  
 (c) Electrons are majority carriers and trivalent atoms are dopants.  
 (d) Electrons are minority carriers and pentavalent atoms are dopants. (NEET 2013)
12. If a small amount of antimony is added to germanium crystal  
 (a) it becomes a  $p$ -type semiconductor  
 (b) the antimony becomes an acceptor atom  
 (c) there will be more free electrons than holes in the semiconductor  
 (d) its resistance is increased. (2011)
13. Pure Si at 500 K has equal number of electron ( $n_e$ ) and hole ( $n_h$ ) concentrations of  $1.5 \times 10^{16} \text{ m}^{-3}$ . Doping by indium increases  $n_h$  to  $4.5 \times 10^{22} \text{ m}^{-3}$ . The doped semiconductor is of  
 (a)  $p$ -type having electron concentration  
 $n_e = 5 \times 10^9 \text{ m}^{-3}$   
 (b)  $n$ -type with electron concentration  
 $n_e = 5 \times 10^{22} \text{ m}^{-3}$   
 (c)  $p$ -type with electron concentration  
 $n_e = 2.5 \times 10^{10} \text{ m}^{-3}$   
 (d)  $n$ -type with electron concentration  
 $n_e = 2.5 \times 10^{23} \text{ m}^{-3}$  (Mains 2011)
14. Which one of the following statement is false?  
 (a) Pure Si doped with trivalent impurities gives a  $p$ -type semiconductor.  
 (b) Majority carriers in a  $n$ -type semiconductor are holes.  
 (c) Minority carriers in a  $p$ -type semiconductor are electrons.  
 (d) The resistance of intrinsic semiconductor decreases with increase of temperature. (2010)
15. In the energy band diagram of a material shown here, the open circles and filled circles denote holes and electrons respectively. The material is
- 
- (a) an insulator  
 (b) a metal  
 (c) an  $n$ -type semiconductor  
 (d) a  $p$ -type semiconductor. (2007)
16. In a  $p$  type semiconductor, the majority carriers of current are  
 (a) protons (b) electrons  
 (c) holes (d) neutrons (1999)
17. Which of the following, when added as an impurity into the silicon produces  $n$  type semiconductor?  
 (a) B (b) Al  
 (c) P (d) Mg (1999)
18. To obtain a  $p$ -type germanium semiconductor, it must be doped with  
 (a) indium (b) phosphorus  
 (c) arsenic (d) antimony. (1997)
19. When arsenic is added as an impurity to silicon, the resulting material is  
 (a)  $n$ -type conductor  
 (b)  $n$ -type semiconductor  
 (c)  $p$ -type semiconductor  
 (d) none of these. (1996)
20. When  $n$  type semiconductor is heated  
 (a) number of electrons increases while that of holes decreases  
 (b) number of holes increases while that of electrons decreases  
 (c) number of electrons and holes remain same  
 (d) number of electrons and holes increases equally. (1989)

### 14.5 p-n Junction

21. The increase in the width of the depletion region in a  $p$ - $n$  junction diode is due to  
 (a) forward bias only  
 (b) reverse bias only  
 (c) both forward bias and reverse bias  
 (d) increase in forward current (NEET 2020)
22. The barrier potential of a  $p$ - $n$  junction depends on  
 (1) type of semiconductor material  
 (2) amount of doping  
 (3) temperature  
 Which one of the following is correct?  
 (a) (1) and (2) only (b) (2) only  
 (c) (2) and (3) only (d) (1), (2) and (3) (2014)
23. In an unbiased  $p$ - $n$  junction, holes diffuse from the  $p$ -region to  $n$ -region because of  
 (a) the attraction of free electrons of  $n$ -region  
 (b) the higher hole concentration in  $p$ -region than that in  $n$ -region

- (c) the higher concentration of electrons in the  $n$ -region than that in the  $p$ -region
- (d) the potential difference across the  $p$ - $n$  junction. (Karnataka NEET 2013)

24. In a  $p$ - $n$  junction
- (a) high potential at  $n$  side and low potential at  $p$  side
  - (b) high potential at  $p$  side and low potential at  $n$  side
  - (c)  $p$  and  $n$  both are at same potential
  - (d) undetermined. (2002)
25. Depletion layer consists of
- (a) mobile ions (b) protons
  - (c) electrons (d) immobile ions (1999)
26. The depletion layer in the  $p$ - $n$  junction region is caused by
- (a) drift of holes
  - (b) diffusion of charge carriers
  - (c) migration of impurity ions
  - (d) drift of electrons. (1991)

### 14.6 Semiconductor Diode

27. In a  $p$ - $n$  junction diode, change in temperature due to heating
- (a) affects only reverse resistance
  - (b) affects only forward resistance
  - (c) does not affect resistance of  $p$ - $n$  junction
  - (d) affects the overall  $V - I$  characteristics of  $p$ - $n$  junction. (NEET 2018)

28. Which one of the following represents forward bias diode?

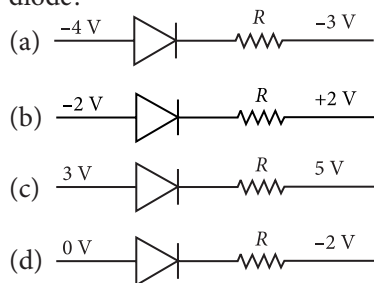

(NEET 2017, 2006)

29. The given circuit has two ideal diodes connected as shown in the figure. The current flowing through the resistance  $R_1$  will be

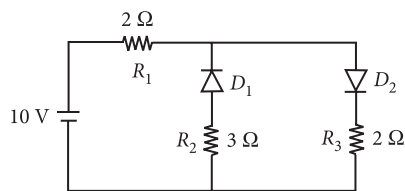

- (a) 2.5 A (b) 10.0 A
- (c) 1.43 A (d) 3.13 A

(NEET-II 2016)

30. Consider the junction diode as ideal. The value of current flowing through  $AB$  is

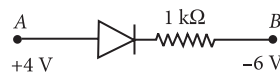

- (a)  $10^{-1}$  A (b)  $10^{-3}$  A
- (c) 0 A (d)  $10^{-2}$  A (NEET-I 2016)

31. In the given figure, a diode  $D$  is connected to an external resistance  $R = 100 \Omega$  and an e.m.f. of 3.5 V. If the barrier potential developed across the diode is 0.5 V, the current in the circuit will be

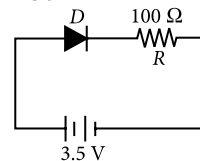

(2015)

- (a) 20 mA
- (b) 35 mA
- (c) 30 mA
- (d) 40 mA

32. If in a  $p$ - $n$  junction, a square input signal of 10 V is applied, as shown,

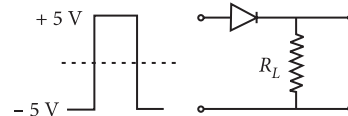

then the output across  $R_L$  will be

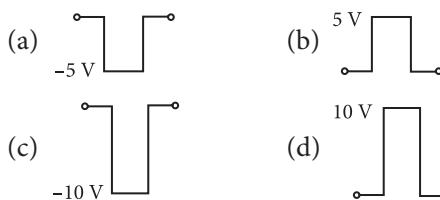

(2015 Cancelled)

33. Two ideal diodes are connected to a battery as shown in the circuit. The current supplied by the battery is

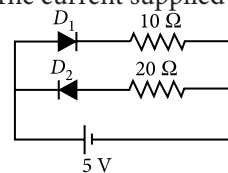

- (a) 0.75 A (b) zero
- (c) 0.25 A (d) 0.5 A (2012)

34. In forward biasing of the  $p$ - $n$  junction
- (a) the positive terminal of the battery is connected to  $p$ -side and the depletion region becomes thick.
  - (b) the positive terminal of the battery is connected to  $n$ -side and the depletion region becomes thin.
  - (c) the positive terminal of the battery is connected to  $n$ -side and the depletion region becomes thick.
  - (d) the positive terminal of the battery is connected to  $p$ -side and the depletion region becomes thin. (2011, 1988)

35. In the following figure, the diodes which are forward biased, are

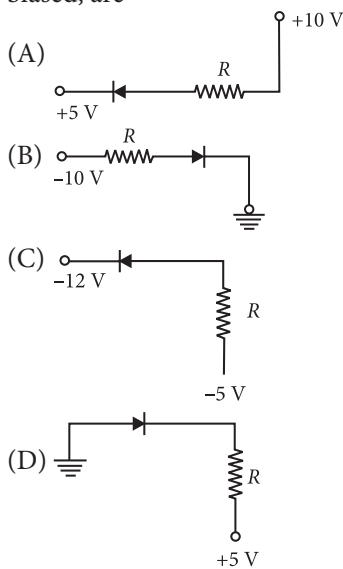

- (a) (A), (B) and (D)      (b) (C) only  
 (c) (C) and (A)          (d) (B) and (D)

(Mains 2011)

36. Application of a forward bias to a  $p-n$  junction

- (a) widens the depletion zone  
 (b) increases the potential difference across the depletion zone  
 (c) increases the number of donors on the  $n$  side  
 (d) decreases the electric field in the depletion zone.

(2005)

37. Of the diodes shown in the following diagrams, which one is reverse biased ?

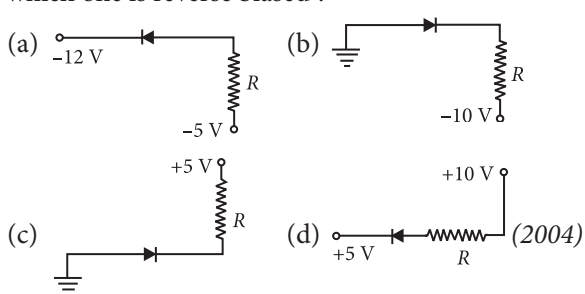

38. Reverse bias applied to a junction diode

- (a) lowers the potential barrier  
 (b) raises the potential barrier  
 (c) increases the majority carrier current  
 (d) increases the minority carrier current

(2003)

39. Barrier potential of a  $p-n$  junction diode does not depend on

- (a) diode design              (b) temperature  
 (c) forward bias              (d) doping density

(2003)

40. For the given circuit of  $p-n$  junction diode which is correct?

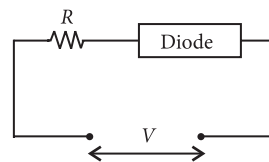

- (a) In forward bias the voltage across  $R$  is  $V$ .  
 (b) In reverse bias the voltage across  $R$  is  $V$ .  
 (c) In forward bias the voltage across  $R$  is  $2V$ .  
 (d) In reverse bias the voltage across  $R$  is  $2V$ .

(2002)

41. The current in the circuit will be

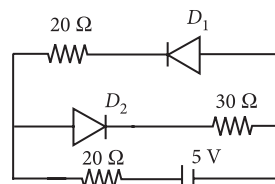

- (a)  $5/40\text{ A}$                       (b)  $5/50\text{ A}$   
 (c)  $5/10\text{ A}$                       (d)  $5/20\text{ A}$

(2001)

42. From the following diode circuit, which diode is in forward biased condition

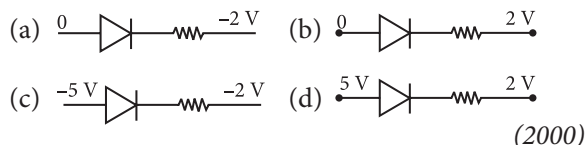

(2000)

43. In forward bias, the width of potential barrier in a  $p-n$  junction diode

- (a) remains constant      (b) decreases  
 (c) increases                  (d) first (a) then (b)

(1999)

44. In a junction diode, the holes are due to

- (a) extra electrons          (b) neutrons  
 (c) protons                      (d) missing of electrons

(1999)

45. The cause of the potential barrier in a  $p-n$  junction diode is

- (a) depletion of negative charges near the junction  
 (b) concentration of positive charges near the junction  
 (c) depletion of positive charges near the junction  
 (d) concentration of positive and negative charges near the junction.

(1998)

46. A semiconducting device is connected in a series circuit with a battery and a resistance. A current is found to pass through the circuit. If the polarity of the battery is reversed, the current drops to almost zero. The device may be

- (a) a  $p$ -type semiconductor  
 (b) an intrinsic semiconductor  
 (c) a  $p-n$  junction  
 (d) an  $n$ -type semiconductor.

(1998)

47. The diode used in the circuit shown in the figure has a constant voltage drop at 0.5 V at all currents and a maximum power rating of 100 milli watts. What should be the value of the resistor  $R$ , connected in series with diode for obtaining maximum current?

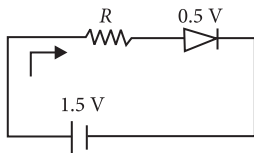

- (a)  $6.76 \Omega$  (b)  $20 \Omega$   
(c)  $5 \Omega$  (d)  $5.6 \Omega$ . (1997)

48. In the case of forward biasing of  $p$ - $n$  junction, which one of the following figures correctly depicts the direction of flow of carriers?

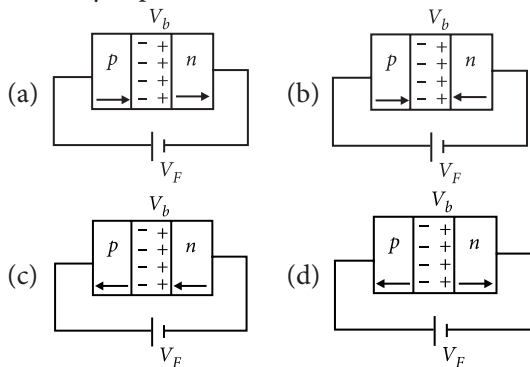

(1995)

### 14.7 Application of Junction Diode as a Rectifier

49. The peak voltage in the output of a half wave diode rectifier fed with a sinusoidal signal without filter is 10 V. The d.c. component of the output voltage is  
(a)  $10/\sqrt{2}$  V (b)  $10/\pi$  V  
(c) 10 V (d)  $20/\pi$  V (2004)
50. If a full wave rectifier circuit is operating from 50 Hz mains, the fundamental frequency in the ripple will be  
(a) 25 Hz (b) 50 Hz  
(c) 70.7 Hz (d) 100 Hz (2003)
51. A  $p$ - $n$  junction diode can be used as  
(a) condenser (b) regulator  
(c) amplifier (d) rectifier (1999)

### 14.8 Special Purpose $p$ - $n$ Junction Diodes

52. An LED is constructed from a  $p$ - $n$  junction diode using GaAsP. The energy gap is 1.9 eV. The wavelength of the light emitted will be equal to  
(a)  $10.4 \times 10^{-26}$  m (b) 654 nm  
(c) 654 Å (d)  $654 \times 10^{-11}$  m  
(Odisha NEET 2019)

53. The given graph represents  $V$ - $I$  characteristic for a semiconductor device. Which of the following statement is correct?

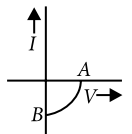

- (a) It is  $V$ - $I$  characteristic for solar cell where, point A represents open circuit voltage and point B short circuit current.  
(b) It is for a solar cell and points A and B represent open circuit voltage and current, respectively.  
(c) It is for a photodiode and points A and B represent open circuit voltage and current, respectively.  
(d) It is for a LED and points A and B represent open circuit voltage and short circuit current, respectively. (2014)
54. A Zener diode, having breakdown voltage equal to 15V, is used in a voltage regulator circuit shown in figure. The current through the diode is

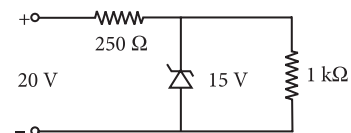

- (a) 5 mA (b) 10 mA  
(c) 15 mA (d) 20 mA (Mains 2011)
55. A  $p$ - $n$  photodiode is fabricated from a semiconductor with a band gap of 2.5 eV. It can detect a signal of wavelength  
(a) 4000 nm (b) 6000 nm  
(c) 4000 Å (d) 6000 Å (2009)
56. A  $p$ - $n$  photodiode is made of a material with a band gap of 2.0 eV. The minimum frequency of the radiation that can be absorbed by the material is nearly  
(a)  $1 \times 10^{14}$  Hz (b)  $20 \times 10^{14}$  Hz  
(c)  $10 \times 10^{14}$  Hz (d)  $5 \times 10^{14}$  Hz (2008)
57. Zener diode is used for  
(a) amplification  
(b) rectification  
(c) stabilisation  
(d) producing oscillations in an oscillator. (2005)
58. In a  $p$ - $n$  junction photo cell, the value of the photo-electromotive force produced by monochromatic light is proportional to  
(a) the barrier voltage at the  $p$ - $n$  junction  
(b) the intensity of the light falling on the cell  
(c) the frequency of the light falling on the cell  
(d) the voltage applied at the  $p$ - $n$  junction. (2005)

**14.9 Digital Electronics and Logic Gates**

59. For the logic circuit shown, the truth table is

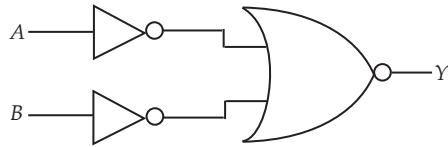

- (a) 

A	B	Y
0	0	0
0	1	0
1	0	0
1	1	1
- (b) 

A	B	Y
0	0	0
0	1	1
1	0	1
1	1	1
- (c) 

A	B	Y
0	0	1
0	1	1
1	0	1
1	1	0
- (d) 

A	B	Y
0	0	1
0	1	0
1	0	0
1	1	0

(NEET 2020)

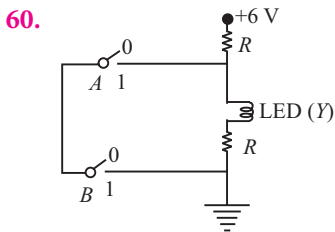

The correct Boolean operation represented by the circuit diagram drawn is

- (a) NOR (b) AND  
(c) OR (d) NAND (NEET 2019)

61. In the combination of the following gates the output Y can be written in terms of inputs A and B as

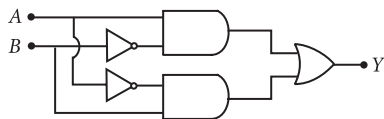

- (a)  $\overline{A \cdot B}$  (b)  $A \cdot \overline{B} + \overline{A} \cdot B$   
(c)  $\overline{A \cdot B} + A \cdot B$  (d)  $\overline{A + B}$  (NEET 2018)

62. The given electrical network is equivalent to



- (a) OR gate (b) NOR gate  
(c) NOT gate (d) AND gate (NEET 2017)

63. What is the output Y in the following circuit, when all the three inputs A, B, C are first 0 and then 1 ?

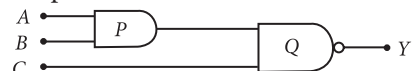

- (a) 0, 1 (b) 0, 0 (c) 1, 0 (d) 1, 1 (NEET-II 2016)

64. To get output 1 for the following circuit, the correct choice for the input is

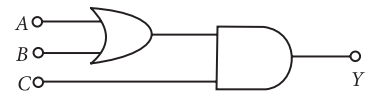

- (a)  $A = 1, B = 1, C = 0$  (b)  $A = 1, B = 0, C = 1$   
(c)  $A = 0, B = 1, C = 0$  (d)  $A = 1, B = 0, C = 0$   
(NEET-I 2016, Mains 2012, 2010)

65. The output (X) of the logic circuit shown in figure will be

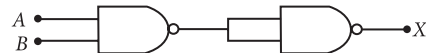

- (a)  $X = A \cdot B$  (b)  $X = \overline{A + B}$   
(c)  $X = \overline{\overline{A \cdot B}}$  (d)  $X = \overline{A \cdot B}$  (NEET 2013)

66. The output from of a NAND gate is divided into two in parallel and fed to another NAND gate. The resulting gate is a

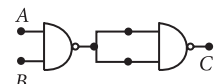

- (a) AND gate (b) NOR gate  
(c) OR gate (d) NOT gate (Karnataka NEET 2013)

67. The figure shows a logic circuit with two inputs A and B and the output C. The voltage wave forms across A, B and C are as given. The logic circuit gate is

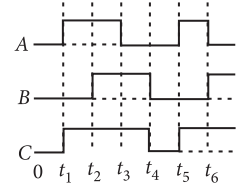

- (a) OR gate (b) NOR gate  
(c) AND gate (d) NAND gate (2012)

68. Symbolic representation of four logic gates are shown as

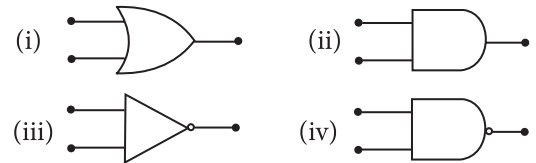

Pick out which ones are for AND, NAND and NOT gates, respectively

- (a) (ii), (iii) and (iv) (b) (iii), (ii) and (i)  
(c) (iii), (ii) and (iv) (d) (ii), (iv) and (iii) (2011)

69. The device that can act as a complete electronic circuit is

- (a) junction diode (b) integrated circuit  
(c) junction transistor (d) zener diode. (2010)

70. The following figure shows a logic gate circuit with two inputs A and B and the output Y. The voltage waveforms of A, B and Y are as given.

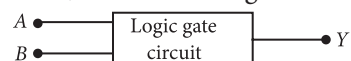

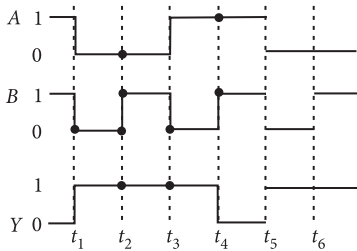

The logic gate is  
 (a) NOR gate (b) OR gate  
 (c) AND gate (d) NAND gate  
 (Mains 2010)

71. The symbolic representation of four logic gates are given here

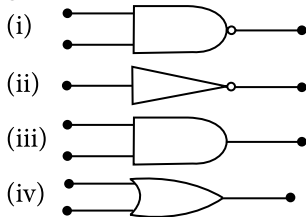

The logic symbols for OR, NOT and NAND gates are respectively  
 (a) (iv), (i), (iii) (b) (iv), (ii), (i)  
 (c) (i), (iii), (iv) (d) (iii), (iv), (ii) (2009)

72. In the following circuit, the output Y for all possible inputs A and B is expressed by the truth table.

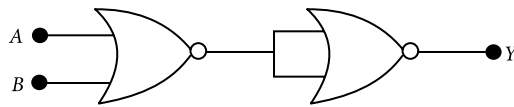

A	B	Y	A	B	Y
0	0	1	0	0	1
0	1	1	0	1	0
1	0	1	1	0	0
1	1	0	1	1	0
A	B	Y	A	B	Y
0	0	0	0	0	0
0	1	1	0	1	0
1	0	1	1	0	0
1	1	1	1	1	1

73. The following figure shows a logic gate circuit with two inputs A and B and the output C.

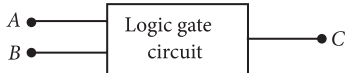

The voltage waveforms of A, B and C are as shown

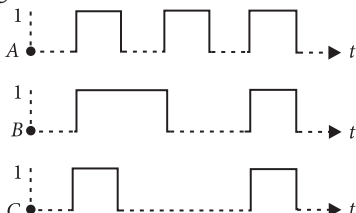

The logic circuit gate is  
 (a) OR gate (b) AND gate  
 (c) NAND gate (d) NOR gate. (2006)

74. The output of OR gate is 1  
 (a) if both inputs are zero  
 (b) if either or both inputs are 1  
 (c) only if both inputs are 1  
 (d) if either input is zero. (2004)

75. The given truth table is for which logic gate?

A	B	Y
1	1	0
0	1	1
1	0	1
0	0	1

(a) NAND  
 (b) XOR  
 (c) NOR  
 (d) OR  
 (2002, 2001, 1998, 1994)

76. Which of the following gates will have an output of 1?

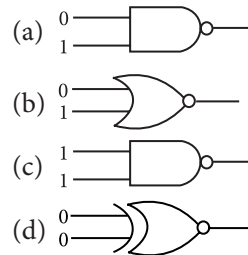

(1998)

77. The following truth-table belongs to which one of the following four gates?

A	B	Y
1	1	0
1	0	0
0	1	0
0	0	1

(a) XOR  
 (b) NOR  
 (c) OR  
 (d) NAND  
 (1997, 1995)

78. This symbol represents



(a) AND gate  
 (b) NOR gate  
 (c) NAND gate  
 (d) OR gate. (1996)

79. The following truth table corresponds to the logical gate

A	B	Y
0	0	0
0	1	1
1	0	1
1	1	1

(a) NAND (b) OR  
 (c) AND (d) XOR. (1991)

### 14.A Junction Transistor

80. For transistor action, which of the following statements is correct?

(a) Base, emitter and collector regions should have same doping concentrations.

- (b) Base, emitter and collector regions should have same size.  
 (c) Both emitter junction as well as the collector junction are forward biased.  
 (d) The base region must be very thin and lightly doped. (NEET 2020)

81. In the circuit shown in the figure, the input voltage  $V_i$  is 20 V,  $V_{BE} = 0$  and  $V_{CE} = 0$ . The values of  $I_B$ ,  $I_C$  and  $\beta$  are given by

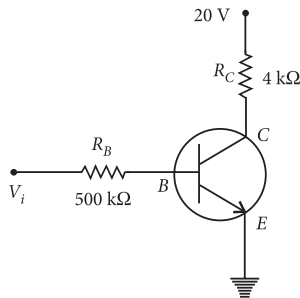

- (a)  $I_B = 40 \mu\text{A}$ ,  $I_C = 10 \text{ mA}$ ,  $\beta = 250$   
 (b)  $I_B = 25 \mu\text{A}$ ,  $I_C = 5 \text{ mA}$ ,  $\beta = 200$   
 (c)  $I_B = 20 \mu\text{A}$ ,  $I_C = 5 \text{ mA}$ ,  $\beta = 250$   
 (d)  $I_B = 40 \mu\text{A}$ ,  $I_C = 5 \text{ mA}$ ,  $\beta = 125$  (NEET 2018)

82. In a common emitter transistor amplifier the audio signal voltage across the collector is 3 V. The resistance of collector is  $3 \text{ k}\Omega$ . If current gain is 100 and the base resistance is  $2 \text{ k}\Omega$ , the voltage and power gain of the amplifier is  
 (a) 15 and 200 (b) 150 and 15000  
 (c) 20 and 2000 (d) 200 and 1000 (NEET 2017)

83. For CE transistor amplifier, the audio signal voltage across the collector resistance of  $2 \text{ k}\Omega$  is 4 V. If the current amplification factor of the transistor is 100 and the base resistance is  $1 \text{ k}\Omega$ , then the input signal voltage is  
 (a) 10 mV (b) 20 mV  
 (c) 30 mV (d) 15 mV (NEET-II 2016)

84. A npn transistor is connected in common emitter configuration in a given amplifier. A load resistance of  $800 \Omega$  is connected in the collector circuit and the voltage drop across it is 0.8 V. If the current amplification factor is 0.96 and the input resistance of the circuit is  $192 \Omega$ , the voltage gain and the power gain of the amplifier will respectively be  
 (a) 4, 4 (b) 4, 3.69  
 (c) 4, 3.84 (d) 3.69, 3.84 (NEET-I 2016)

85. The input signal given to a CE amplifier having a voltage gain of 150 is  $V_i = 2\cos\left(15t + \frac{\pi}{3}\right)$ . The corresponding output signal will be

- (a)  $2\cos\left(15t + \frac{5\pi}{6}\right)$  (b)  $300\cos\left(15t + \frac{4\pi}{3}\right)$

- (c)  $300\cos\left(15t + \frac{\pi}{3}\right)$  (d)  $75\cos\left(15t + \frac{2\pi}{3}\right)$  (2015)

86. In a common emitter (CE) amplifier having a voltage gain  $G$ , the transistor used has transconductance  $0.03 \text{ mho}$  and current gain 25. If the above transistor is replaced with another one with transconductance  $0.02 \text{ mho}$  and current gain 20, the voltage gain will be  
 (a)  $\frac{1}{3}G$  (b)  $\frac{5}{4}G$  (c)  $\frac{2}{3}G$  (d)  $1.5G$  (NEET 2013)

87. One way in which the operation of a  $n-p-n$  transistor differs from that of a  $p-n-p$   
 (a) The emitter junction injects minority carriers into the base region of the  $p-n-p$   
 (b) The emitter injects holes into the base of the  $p-n-p$  and electrons into the base region of  $n-p-n$   
 (c) The emitter injects holes into the base of  $n-p-n$   
 (d) The emitter junction is reversed biased in  $n-p-n$  (Karnataka NEET 2013)

88. In a CE transistor amplifier, the audio signal voltage across the collector resistance of  $2 \text{ k}\Omega$  is 2 V. If the base resistance is  $1 \text{ k}\Omega$  and the current amplification of the transistor is 100, the input signal voltage is  
 (a) 0.1 V (b) 1.0 V  
 (c) 1 mV (d) 10 mV (2012)

89. Transfer characteristics [output voltage ( $V_o$ ) versus input voltage ( $V_i$ )] for a base biased transistor in CE configuration is as shown in the figure. For using transistor as a switch, it is used  
 (a) in region III  
 (b) both in region (I) and (III)  
 (c) in region II  
 (d) in region I (2012)

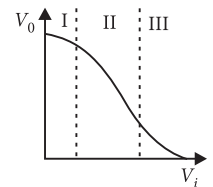

90. The input resistance of a silicon transistor is  $100 \Omega$ . Base current is changed by  $40 \mu\text{A}$  which results in a change in collector current by 2 mA. This transistor is used as a common emitter amplifier with a load resistance of  $4 \text{ k}\Omega$ . The voltage gain of the amplifier is  
 (a) 2000 (b) 3000  
 (c) 4000 (d) 1000 (Mains 2012)

91. A transistor is operated in common emitter configuration at  $V_C = 2 \text{ V}$  such that a change in the base current from  $100 \mu\text{A}$  to  $300 \mu\text{A}$  produces a change in the collector current from 10 mA to 20 mA. The current gain is  
 (a) 50 (b) 75 (c) 100 (d) 25 (2011)

92. A common emitter amplifier has a voltage gain of 50, an input impedance of  $100 \Omega$  and an output impedance of  $200 \Omega$ . The power gain of the amplifier is  
 (a) 500 (b) 1000  
 (c) 1250 (d) 50 (2010)



93. For transistor action
- (1) Base, emitter and collector regions should have similar size and doping concentrations.
  - (2) The base region must be very thin and lightly doped.
  - (3) The emitter-base junction is forward biased and base-collector junction is reverse biased.
  - (4) Both the emitter-base junction as well as the base-collector junction are forward biased.
- Which one of the following pairs of statements is correct?
- (a) (4) and (1)                      (b) (1) and (2)  
 (c) (2) and (3)                      (d) (3) and (4)  
 (Mains 2010)
94. A transistor is operated in common-emitter configuration at  $V_C = 2$  V such that a change in the base current from  $100 \mu\text{A}$  to  $200 \mu\text{A}$  produces a change in the collector current from  $5$  mA to  $10$  mA. The current gain is
- (a) 100                                  (b) 150  
 (c) 50                                    (d) 75                                  (2009)
95. The voltage gain of an amplifier with 9% negative feedback is 10. The voltage gain without feedback will be
- (a) 1.25    (b) 100    (c) 90    (d) 10 (2008)
96. A transistor is operated in common emitter configuration at constant collector voltage  $V_C = 1.5$  V such that a change in the base current from  $00 \mu\text{A}$  to  $150 \mu\text{A}$  produces a change in the collector current from  $5$  mA to  $10$  mA. The current gain  $\beta$  is
- (a) 50                                  (b) 67  
 (c) 75                                  (d) 100                                (2006)
97. A  $n$ - $p$ - $n$  transistor conducts when
- (a) both collector and emitter are positive with respect to the base
  - (b) collector is positive and emitter is negative with respect to the base
  - (c) collector is positive and emitter is at same potential as the base
  - (d) both collector and emitter are negative with respect to the base.                      (2003)
98. For a transistor  $\frac{I_C}{I_E} = 0.96$ , then current gain for common emitter is
- (a) 12                                  (b) 6  
 (c) 48                                  (d) 24                                (2002)
99. For a common base circuit if  $\frac{I_C}{I_E} = 0.98$  then current gain for common emitter circuit will be
- (a) 49                                  (b) 98  
 (c) 4.9                                (d) 25.5                              (2001)
100. The correct relation for  $\alpha$ ,  $\beta$  for a transistor
- (a)  $\beta = \frac{1-\alpha}{\alpha}$                               (b)  $\beta = \frac{\alpha}{1-\alpha}$
- (c)  $\alpha = \frac{\beta-1}{\beta}$                               (d)  $\alpha\beta = 1$ .                              (2000)
101. The transfer ratio  $\beta$  of a transistor is 50. The input resistance of the transistor when used in the common-emitter configuration is  $1$  k $\Omega$ . The peak value of the collector A.C. current for an A.C. input voltage of  $0.01$  V peak is
- (a)  $0.25$  mA                              (b)  $0.01$  mA  
 (c)  $100$  mA                                (d)  $500$  mA                              (1998)
102. When  $n$ pn transistor is used as an amplifier, then
- (a) electrons move from collector to base
  - (b) holes move from base to emitter
  - (c) electrons move from base to collector
  - (d) electrons move from emitter to base.                      (1996)
103. The part of the transistor which is heavily doped to produce large number of majority carriers is
- (a) emitter                                (b) base  
 (c) collector  
 (d) any of the above depending upon the nature of transistor                                  (1993)
104. To use a transistor as an amplifier
- (a) the emitter base junction is forward biased and the base collector junction is reversed biased
  - (b) no bias voltage is required
  - (c) both junction are forward biased
  - (d) both junction are reverse biased.                      (1991)
105. In a common base amplifier the phase difference between the input signal voltage and the output voltage is
- (a) 0                                        (b)  $\frac{\pi}{4}$   
 (c)  $\frac{\pi}{2}$                                         (d)  $\pi$                                         (1990)
106. Radiowaves of constant amplitude can be generated with
- (a) FET                                      (b) filter  
 (c) rectifier                                (d) oscillator                              (1989)

### 14.B Solids

107. Which one of the following bonds produces a solid that reflects light in the visible region and whose electrical conductivity decreases with temperature and has high melting point?
- (a) metallic bonding
  - (b) van der Waal's bonding
  - (c) ionic bonding
  - (d) covalent bonding                      (2010)
108. Sodium has body centred packing. Distance between two nearest atoms is  $3.7 \text{ \AA}$ . The lattice parameter is
- (a)  $4.3 \text{ \AA}$                                   (b)  $3.0 \text{ \AA}$   
 (c)  $8.6 \text{ \AA}$                                 (d)  $6.8 \text{ \AA}$                               (2009, 1999)
109. If the lattice parameter for a crystalline structure is  $3.6 \text{ \AA}$ , then the atomic radius in fcc crystal is

- (a) 2.92 Å (b) 1.27 Å  
(c) 1.81 Å (d) 2.10 Å (2008)
- 110.** For a cubic crystal structure which one of the following relations indicating the cell characteristics is correct?  
(a)  $a \neq b \neq c$  and  $\alpha = \beta = \gamma = 90^\circ$   
(b)  $a = b = c$  and  $\alpha \neq \beta \neq \gamma = 90^\circ$   
(c)  $a = b = c$  and  $\alpha = \beta = \gamma = 90^\circ$   
(d)  $a \neq b \neq c$  and  $\alpha \neq \beta$  and  $\gamma \neq 90^\circ$ . (2007)
- 111.** Copper has face centered cubic (fcc) lattice with interatomic spacing equal to 2.54 Å. The value of lattice constant for this lattice is  
(a) 2.54 Å (b) 3.59 Å  
(c) 1.27 Å (d) 5.08 Å. (2005)
- 112.** Number of atom per unit cell in B.C.C.  
(a) 9 (b) 4 (c) 2 (d) 1 (2002)
- 113.** The cations and anions are arranged in alternate form in  
(a) metallic crystal  
(b) ionic crystal  
(c) covalent crystal  
(d) semi-conductor crystal. (2000)
- 114.** Distance between body centred atom and a corner atom in sodium ( $a = 4.225$  Å) is  
(a) 2.99 Å (b) 2.54 Å  
(c) 3.66 Å (d) 3.17 Å. (1995)
- 115.** Diamond is very hard because  
(a) it is covalent solid  
(b) it has large cohesive energy  
(c) high melting point  
(d) insoluble in all solvents. (1993)
- 116.** Which one of the following is the weakest kind of the bonding in solids?  
(a) ionic (b) metallic  
(c) van der Waals (d) covalent (1992)

### ANSWER KEY

1. (b) 2. (b) 3. (a) 4. (b) 5. (c) 6. (a) 7. (a) 8. (c) 9. (c) 10. (c)  
11. (a) 12. (c) 13. (a) 14. (b) 15. (d) 16. (c) 17. (c) 18. (a) 19. (b) 20. (d)  
21. (b) 22. (d) 23. (b) 24. (a) 25. (d) 26. (b) 27. (d) 28. (d) 29. (a) 30. (d)  
31. (c) 32. (b) 33. (d) 34. (d) 35. (c) 36. (d) 37. (c) 38. (b) 39. (a) 40. (a)  
41. (b) 42. (a) 43. (b) 44. (d) 45. (d) 46. (c) 47. (c) 48. (b) 49. (b) 50. (d)  
51. (d) 52. (b) 53. (a) 54. (a) 55. (c) 56. (d) 57. (c) 58. (b) 59. (a) 60. (d)  
61. (b) 62. (b) 63. (c) 64. (b) 65. (a) 66. (a) 67. (a) 68. (d) 69. (b) 70. (d)  
71. (b) 72. (c) 73. (b) 74. (b) 75. (a) 76. (a) 77. (b) 78. (c) 79. (b) 80. (d)  
81. (d) 82. (b) 83. (b) 84. (c) 85. (b) 86. (c) 87. (b) 88. (d) 89. (b) 90. (a)  
91. (a) 92. (c) 93. (c) 94. (c) 95. (b) 96. (d) 97. (b) 98. (d) 99. (a) 100. (b)  
101. (d) 102. (c) 103. (a) 104. (a) 105. (a) 106. (d) 107. (a) 108. (a) 109. (b) 110. (c)  
111. (b) 112. (c) 113. (b) 114. (c) 115. (b) 116. (c)

## Hints & Explanations

1. (b)  
2. (b): The amplifying action of a triode is based on the fact that a small change in grid voltage causes a large change in plate current. The AC input signal which is to be amplified is superimposed on the grid potential.  
3. (a): According to Child's Law,  $I = KV^{3/2}$   
Thus  $I \propto V^{3/2}$   
4. (b): Voltage gain of an amplifier  
$$= \frac{\text{Output voltage}}{\text{Input voltage}} = - \frac{\mu R_L}{R_L + r_p}$$
  
The negative sign indicates that the output voltage differs

in phase from the input voltage by  $180^\circ(\pi)$ . This holds for a pure resistive load.

5. (c): Resistivity of a semiconductor decreases with increase in the temperature.

6. (a): Band gap of carbon is 5.5 eV while that of silicon is 1.1 eV.

$$(E_g)_C > (E_g)_{Si}$$

7. (a): In semiconductors at room temperature the electrons get enough energy so that they are able to overcome the forbidden gap. Thus at room temperature the valence band is partially empty and conduction band is



partially filled. Conduction band in semiconductor is completely empty only at 0 K.

**8. (c) :** Electronic configuration of carbon ( ${}^6\text{C}$ ) is  $1s^2 2s^2 2p^2$ . The electronic configuration of silicon ( ${}_{14}\text{Si}$ ) is  $1s^2 2s^2 2p^6 3s^2 3p^2$ .

Hence, the four bonding electrons of C and Si respectively lie in second and third orbit.

**9. (c) :** Semiconductors are insulators at room temperature.

**10. (c) :** In  $p$ -type semiconductors, holes are the majority carriers and trivalent atoms are the dopants such as B, Al or Ga.

**11. (a) :** In  $n$ -type semiconductor, electrons are majority charge carriers and holes are minority charge carriers and pentavalent atoms are dopants.

**12. (c) :** When a small amount of antimony (pentavalent) is added to germanium (tetravalent) crystal, then crystal becomes  $n$ -type semiconductor. In  $n$ -type semiconductor electrons are the majority charge carriers and the holes are the minority charge carriers.

**13. (a) :**  $p$ -type semiconductor is obtained when Si or Ge is doped with a trivalent impurity like aluminium (Al), boron (B), indium (In) etc,

Here,  $n_i = 1.5 \times 10^{16} \text{ m}^{-3}$ ,  $n_h = 4.5 \times 10^{22} \text{ m}^{-3}$

As  $n_e n_h = n_i^2$

$$n_e = \frac{n_i^2}{n_h} = \frac{(1.5 \times 10^{16} \text{ m}^{-3})^2}{4.5 \times 10^{22} \text{ m}^{-3}} = 5 \times 10^9 \text{ m}^{-3}$$

**14. (b) :** In a  $n$ -type semiconductors, electrons are majority carriers and holes are minority carriers.

**15. (d) :**  $p$ -type semiconductor.

**16. (c)**

**17. (c) :** Because P (phosphorus) is pentavalent.

**18. (a) :** In  $p$  type germanium semiconductor, it must be doped with a trivalent impurity atom. Since indium is a third group member, therefore germanium must be doped in indium.

**19. (b) :** Arsenic is pentavalent, therefore when added with silicon it leaves one electron as a free electron. In this case the conduction of electricity is due to motion of electrons, so the resulting material is  $n$ -type semiconductor.

**20. (d) :** Due to heating, when a free electron is produced then simultaneously a hole is also produced.

**21. (b) :** Width of the depletion layer increases in reverse biasing.

**22. (d) :** The barrier potential depends on type of semiconductor (For Si,  $V_b = 0.7 \text{ V}$  and for Ge,  $V_b = 0.3 \text{ V}$ ), amount of doping and also on the temperature.

**23. (b) :** The higher hole concentration is in  $p$ -region than that in  $n$ -region.

**24. (a) :**

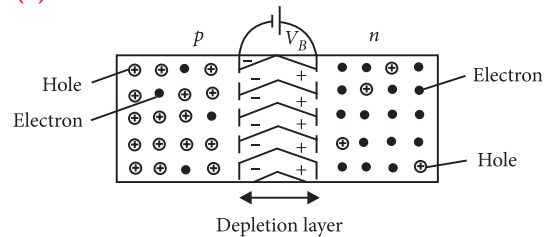

A  $p$ - $n$  junction is shown in the figure. On account of difference in concentration of charge carriers in the two sections of  $p$ - $n$  junction, the electrons from  $n$ -region diffuse through the junction into  $p$ -region and the holes from  $p$ -region diffuse into  $n$  region.

Since the hole is a vacancy of an electron, when an electron from  $n$  region diffuses into the  $p$ -region, the electron falls into the vacancy, i.e., it completes the covalent bond. Due to migration of charge carriers across the junction, the  $n$ -region of the junction will have its electrons neutralized by holes from the  $p$ -region, leaving only ionised donor atoms (positive charges) which are bound and cannot move. Similarly, the  $p$  region of the junction will have ionised acceptor atoms (negative charges) which are immobile.

The accumulation of electric charges of opposite polarities in the two regions of the junction gives rise to an electric field between these regions as if a fictitious battery is connected across the junction with its positive terminal connected to  $n$  region and negative terminal connected to  $p$  region. Therefore, in a  $p$ - $n$  junction high potential is at  $n$  side and low potential is at  $p$  side.

**25. (d)**

**26. (b) :** The depletion layer in the  $p$ - $n$  junction region is caused by diffusion of charge carriers.

**27. (d) :** Due to heating, number of electron-hole pairs will increase, so overall resistance of diode will change.

Due to which forward biasing and reversed biasing both are changed.

**28. (d) :** A diode is said to be forward biased if  $p$ -side is at higher potential than  $n$ -side of  $p$ - $n$  junction.

**29. (a) :** Diode  $D_1$  is reverse biased so, it will block the current and diode  $D_2$  is forward biased, so it will pass the current.

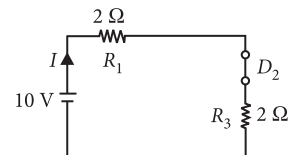

Hence, equivalent circuit becomes as shown in the figure. Current in the circuit = Current flowing through the resistance  $R_1$

$$= \frac{10}{2+2} = 2.5 \text{ A}$$

**30. (d) :** Here, the  $p$ - $n$  junction diode is forward biased, hence it offers zero resistance.

$$\therefore I_{AB} = \frac{V_A - V_B}{R_{AB}} = \frac{4\text{V} - (-6\text{V})}{1 \text{ k}\Omega} = \frac{10}{1000} \text{ A} = 10^{-2} \text{ A}$$



∴ Wavelength of light emitted,

$$\lambda = \frac{1242 \text{ eV-nm}}{1.9 \text{ eV}} = 654 \text{ nm}$$

53. (a) : The V-I characteristic for a solar cell is as shown in the figure.

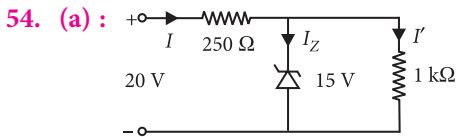
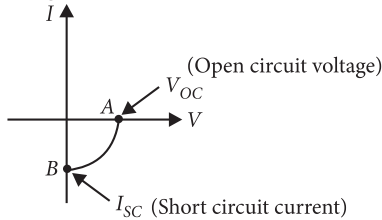

The voltage drop across  $1 \text{ k}\Omega = V_Z = 15 \text{ V}$   
 The current through  $1 \text{ k}\Omega$  is

$$I' = \frac{15 \text{ V}}{1 \times 10^3 \Omega} = 15 \times 10^{-3} \text{ A} = 15 \text{ mA}$$

The voltage drop across  $250 \Omega = 20 \text{ V} - 15 \text{ V} = 5 \text{ V}$

The current through  $250 \Omega$  is

$$I = \frac{5 \text{ V}}{250 \Omega} = 0.02 \text{ A} = 20 \text{ mA}$$

The current through the zener diode is  
 $I_Z = I - I' = (20 - 15) \text{ mA} = 5 \text{ mA}$

55. (c) : Band gap =  $2.5 \text{ eV}$   
 The wavelength corresponding to  $2.5 \text{ eV}$

$$\lambda = \frac{12400 \text{ eV \AA}}{2.5 \text{ eV}} = 4960 \text{ \AA}$$

$4000 \text{ \AA}$  can excite this.

56. (d) : Band gap =  $2 \text{ eV}$ .  
 Wavelength of radiation corresponding to this energy,

$$\lambda = \frac{hc}{E} = \frac{12400 \text{ eV \AA}}{2 \text{ eV}} = 6200 \text{ \AA}$$

The frequency of this radiation

$$\nu = \frac{c}{\lambda} = \frac{3 \times 10^8 \text{ m/s}}{6200 \times 10^{-10} \text{ m/s}} \Rightarrow \nu = 5 \times 10^{14} \text{ Hz}$$

57. (c) : Zener diode is used for stabilisation while p-n junction diode is used for rectification.

58. (b) : In photocell, photoelectromotive force, is the force that stimulates the emission of an electric current when photovoltaic action creates a potential difference between two points and the electric current depends on the intensity of incident light.

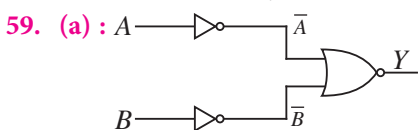

Here,  $Y = \overline{\overline{A} + \overline{B}} = \overline{\overline{A \cdot B}} = A \cdot B$

This AND Gate. So, the truth table is

A	B	Y
0	0	0
0	1	0
1	0	0
1	1	1

60. (d) : LED bulb will light up if switch(s) A or B or both A and B is/are open. Hence it represents a NAND gate.

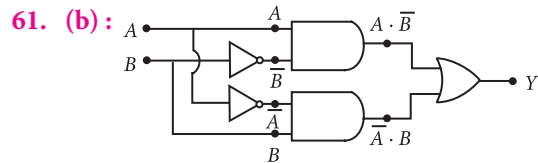

$$Y = (A \cdot \overline{B} + \overline{A} \cdot B)$$

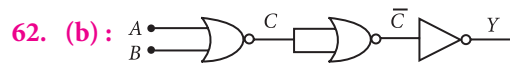

A	B	C	C-bar	Output (Y)
0	0	1	0	1
0	1	0	1	0
1	0	0	1	0
1	1	0	1	0

At output, the truth table corresponds to NOR gate.

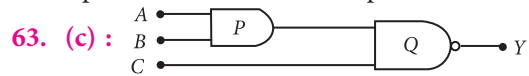

$$Y = \overline{(AB)C} = \overline{ABC}$$

If  $A = B = C = 0$  then  $Y_0 = \overline{0} = 1$

If  $A = B = C = 1$  then  $Y_1 = \overline{1} = 0$

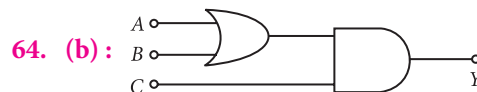

Output of the circuit,  $Y = (A + B) \cdot C$

$Y = 1$  if  $C = 1$  and  $A = 0, B = 1$

or  $A = 1, B = 0$  or  $A = B = 1$



The output of the given logic circuit is

$$X = \overline{A \cdot B} \cdot A = A \cdot \overline{B}$$

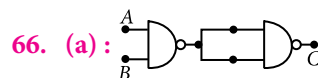

The output of the given logic gate is

$$C = A \cdot B + C = A \cdot B$$

It is the Boolean expression of AND gate.

Hence, the resulting gate is a AND gate.

67. (a) : The truth table of the given waveform is as shown in the table.

Time interval	Input A	Input B	Output C
0 to $t_1$	0	0	0
$t_1$ to $t_2$	1	0	1
$t_2$ to $t_3$	1	1	1
$t_3$ to $t_4$	0	1	1
$t_4$ to $t_5$	0	0	0
$t_5$ to $t_6$	1	0	1
$> t_6$	0	1	1

The logic circuit is OR gate.



It represents logic symbol of OR gate.

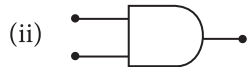

It represents logic symbol of AND gate.

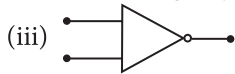

It represents the logic symbol of NOT gate.

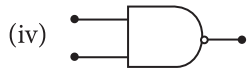

It represents the logic symbol of NAND gate.

69. (b): The device that can act as a complete circuit is integrated circuit (IC).

70. (d): It is clear from given logic circuit, that out put Y is low when both the inputs are high, otherwise z it is high. Thus logic circuit is NAND gate.

A	B	Y
1	1	0
0	0	1
0	1	1
1	0	1

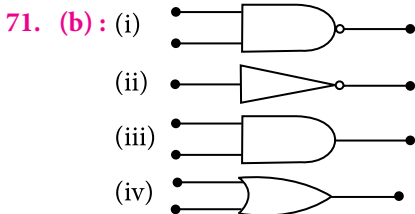

OR gate, NOT gate and NAND gates are (iv), (ii) and (i) respectively.

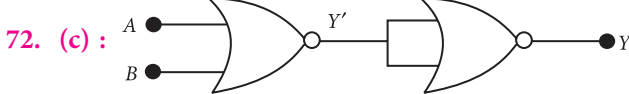

$$Y' = \overline{A + B} \quad Y = \overline{\overline{A + B}} = A + B$$

Truth table of the given circuit is given by

A	B	Y'	Y
0	0	1	0
0	1	0	1
1	0	0	1
1	1	0	1

73. (b): The truth table corresponding to waveform is given by

A	B	C
1	1	1
0	1	0
1	0	0
0	0	0

∴ The given logic circuit gate is AND gate.

74. (b): The truth table of OR gate is

A	B	Y
0	0	0
0	1	1
1	0	1
1	1	1

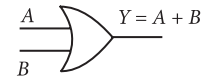

From truth table we can observe that if either of input is one then output is one. Also if both the inputs are one then also output is one.

75. (a): NAND gate is a combination of AND and NOT gate.

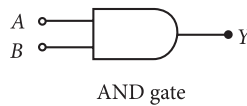

A	B	Y
0	0	0
1	0	0
0	1	0
1	1	1

Truth table of AND gate

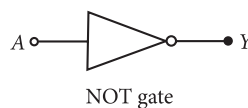

A	Y
0	1
1	0

Truth table of NOT gate

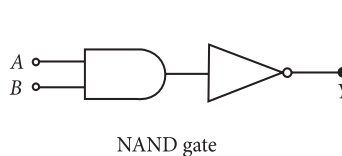

A	B	Y
0	0	1
1	0	1
0	1	1
1	1	0

Truth table of NAND gate

Hence the given truth table is of a NAND gate.

76. (a)

77. (b): For NOR gate,  $Y = \overline{A + B}$ .

Therefore from the given truth table

A	B	A + B	$Y = \overline{A + B}$
1	1	1	0
1	0	1	0
0	1	1	0
0	0	0	1

78. (c): According to figure  $Y = \overline{A \cdot B}$ . Therefore it is NAND gate.

79. (b): This truth table is of identity,  $Y = A + B$ , hence OR gate.

80. (d): For transistor action, emitter has greater doping concentration than collector or base. The base region is made thin and lightly doped so that only a few of electrons recombine.

For the transistor to work in active region, emitter junction is forward biased whereas collector region is reverse biased.

**81. (d) :** Given  $V_{BE} = 0$ ;  $V_{CE} = 0$

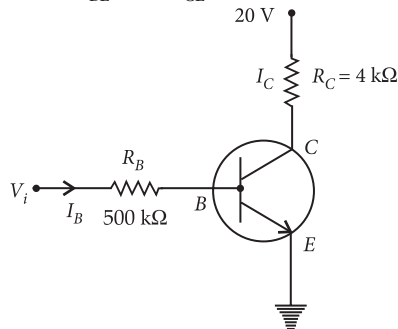

$$\therefore \text{Collector current, } I_C = \frac{(20-0)}{4 \times 10^3}$$

$$\text{or } I_C = 5 \times 10^{-3} \text{ A} = 5 \text{ mA}$$

$$\text{Input voltage, } V_i = V_{BE} + I_B R_B$$

$$\text{or } V_i = 0 + I_B R_B \text{ or } 20 = I_B \times 500 \times 10^3$$

$$\therefore I_B = \frac{20}{500 \times 10^3} = 40 \mu\text{A}$$

$$\therefore \text{Current gain, } \beta = \frac{I_C}{I_B} = \frac{5 \times 10^{-3}}{40 \times 10^{-6}} = 125$$

**82. (b) :** Given:  $V_i = 3 \text{ V}$ ,  $R_C = 3 \text{ k}\Omega$ ,  $R_B = 2 \text{ k}\Omega$ ,  $\beta = 100$

Voltage gain of the CE amplifier,

$$A_V = -\beta_{ac} \left( \frac{R_C}{R_B} \right) = -100 \left( \frac{3}{2} \right) = -150$$

$$\text{Power gain, } A_P = \beta \times A_V = 100 \times (-150) = -15000$$

Negative sign represents that output voltage is in opposite phase with the input voltage.

**83. (b) :** Here,  $R_C = 2 \text{ k}\Omega = 2000 \Omega$ ,  $V_o = 4 \text{ V}$ ,  $\beta = 100$ ,  $R_B = 1 \text{ k}\Omega = 1000 \Omega$ ,  $V_i = ?$

$$\text{Voltage gain, } A = \beta \frac{R_C}{R_B} = 100 \times \frac{2000}{1000} = 200$$

$$\text{Also, } A = \frac{V_o}{V_i} \text{ or } V_i = \frac{V_o}{A} = \frac{4}{200} = \frac{2}{100} \text{ V} = 20 \text{ mV}$$

**84. (c) :** Here,  $R_o = 800 \Omega$ ,  $R_i = 192 \Omega$ , current gain,  $\beta = 0.96$

Voltage gain = Current gain  $\times$  Resistance gain

$$= 0.96 \times \frac{800}{192} = 4$$

Power gain = [Current gain]  $\times$  [Voltage gain]

$$= 0.96 \times 4 = 3.84$$

**85. (b) :** Here, Input signal,  $V_i = 2 \cos \left( 15t + \frac{\pi}{3} \right)$  and voltage gain,  $A_v = 150$

$$\text{As } A_v = \frac{V_o}{V_i}$$

$$\therefore \text{Output signal, } V_o = A_v V_i$$

Since CE amplifier gives a phase difference of  $\pi (=180^\circ)$  between input and output signals,

$$\begin{aligned} \therefore V_o &= 150 \left[ 2 \cos \left( 15t + \frac{\pi}{3} + \pi \right) \right] \\ &= 300 \cos \left( 15t + \frac{4\pi}{3} \right) \end{aligned}$$

**86. (c) :** Voltage gain = Current gain  $\times$  Resistance gain

$$A_v = \beta \times \frac{R_{out}}{R_{in}}$$

$$\text{Transconductance, } g_m = \frac{\beta}{R_{in}} \text{ or } R_{in} = \frac{\beta}{g_m}$$

$$\therefore A_v = g_m R_{out}$$

For first case,  $A_v = G$ ,  $g_m = 0.03 \text{ mho}$ ,  $\beta = 25$

$$\therefore G = 0.03 R_{out} \quad \dots(i)$$

For second case,  $A_v = G'$ ,  $g_m = 0.02 \text{ mho}$ ,  $\beta = 20$

$$\therefore G' = 0.02 R_{out} \quad \dots(ii)$$

Divide (ii) by (i), we get

$$\frac{G'}{G} = \frac{2}{3} \text{ or } G' = \frac{2}{3} G$$

**87. (b) :** The emitter injects electrons into the base region of the  $n-p-n$  transistor and holes into the base region of  $p-n-p$  transistor.

**88. (d) :** Here,  $R_C = 2 \text{ k}\Omega = 2 \times 10^3 \Omega$

$$V_o = 2 \text{ V}, R_B = 1 \text{ k}\Omega = 1 \times 10^3 \Omega, \beta = 100$$

Output voltage,  $V_o = I_C R_C$

$$\text{or } I_C = \frac{V_o}{R_C} = \frac{2 \text{ V}}{2 \times 10^3 \Omega} = 10^{-3} \text{ A} = 1 \text{ mA}$$

$$\text{As } \beta = \frac{I_C}{I_B} \text{ or } I_B = \frac{I_C}{\beta} \text{ or } I_B = \frac{10^{-3} \text{ A}}{100} = 10^{-5} \text{ A}$$

$$\text{Input voltage, } V_i = I_B R_B = (10^{-5} \text{ A}) (1 \times 10^3 \Omega) = 10^{-2} \text{ V} = 10 \text{ mV}$$

**89. (b) :** In the given graph,

Region (I) – Cutoff region

Region (II) – Active region

Region (III) – Saturation region

Using transistor as a switch it is used in cutoff region or saturation region.

Using transistor as an amplifier it is used in active region.

**90. (a) :** Here,

Input resistance,  $R_i = 100 \Omega$

Change in base current,  $\Delta I_B = 40 \mu\text{A}$

Change in collector current,  $\Delta I_C = 2 \text{ mA}$

Load resistance,  $R_L = 4 \text{ k}\Omega = 4 \times 10^3 \Omega$

$$\text{Current gain, } \beta = \frac{\Delta I_C}{\Delta I_B} = \frac{2 \text{ mA}}{40 \mu\text{A}} = \frac{2 \times 10^{-3} \text{ A}}{40 \times 10^{-6} \text{ A}} = 50$$

Voltage gain of the amplifier is

$$A_V = \beta \frac{R_L}{R_i} = 50 \times \frac{4 \times 10^3}{100} = 2000$$

**91. (a) :** Current gain,  $\beta = \frac{\Delta I_C}{\Delta I_B}$

$$= \frac{(20-10) \text{ mA}}{(300-100) \mu\text{A}} = \frac{10 \times 10^{-3} \text{ A}}{200 \times 10^{-6} \text{ A}} = 50$$

92. (c) : Here, Voltage gain = 50

Input resistance,  $R_i = 100 \Omega$

Output resistance,  $R_o = 200 \Omega$

$$\text{Resistance gain} = \frac{R_o}{R_i} = \frac{200 \Omega}{100 \Omega} = 2$$

$$\text{Power gain} = \frac{(\text{Voltage gain})^2}{\text{Resistance gain}} = \frac{50 \times 50}{2} = 1250$$

93. (c)

94. (c) : For common emitter, the current gain is

$$\beta = \left( \frac{\Delta I_C}{\Delta I_B} \right)_{V_{CE}}$$

i.e., at a given potential difference of CE

$$\beta = \frac{(10 \times 10^{-3} - 5 \times 10^{-3}) \text{ A}}{(200 \times 10^{-6} - 100 \times 10^{-6}) \text{ A}} = \frac{5 \times 10^{-3}}{100 \times 10^{-6}} = 50$$

95. (b) : One applies negative feedback, which reduces the output but makes it very stable. For voltage amplification amplifiers the value of output voltage without the negative feedback could be very high. The maximum value shown here is 100.

96. (d) : Current gain,  $\beta = \Delta I_C / \Delta I_B$

$$= \frac{(10 - 5) \text{ mA}}{(150 - 100) \mu\text{A}} = \frac{5 \times 10^{-3}}{50 \times 10^{-6}} = 100$$

97. (b) : A *n-p-n* transistor conducts when emitter-base junction is forward biased while collector-base junction is reverse biased.

98. (d) : The current gain of a common emitter transistor ( $\beta$ ) is defined as the ratio of collector current ( $I_C$ ) to the base current ( $I_B$ ).

Also,  $I_E = I_B + I_C$ ;  $I_C / I_E = 0.96$  (given)

$$\therefore \beta = \frac{I_C}{I_B} = \frac{I_C}{I_E - I_C}$$

$$\text{Now, } \frac{I_E}{I_C} = \frac{1}{0.96} \quad \therefore \frac{I_E - I_C}{I_C} = \frac{1}{0.96} - 1 = \frac{0.04}{0.96}$$

$$\therefore \beta = \frac{I_C}{I_E - I_C} = \frac{0.96}{0.04} = 24$$

$$99. (a) : \frac{I_C}{I_E} = \alpha = 0.98, \quad \frac{I_C}{I_B} = \beta = \frac{\alpha}{1 - \alpha} = 49$$

$$100. (b) : \beta = \frac{I_c}{I_b} = \frac{I_c}{I_e - I_c} = \frac{I_c / I_e}{1 - (I_c / I_e)} = \frac{\alpha}{1 - \alpha}$$

$$101. (d) : I_b = \frac{V_{in}}{R_{in}} = \frac{0.01}{10^3}$$

$$I_c = \beta I_b = 50 \times \frac{0.01}{10^3} = 5 \times 10^{-4} \text{ A} = 500 \text{ mA}$$

102. (c) : In *n-p-n* transistor, the electrons are majority carriers in emitter, which move from base to collector while using *n-p-n* transistor as an amplifier.

103. (a) : The function of emitter is to supply the majority carriers. So, it is heavily doped.

104. (a) : To use transistor as an amplifier the emitter base junction is forward bias while the collector base junction is reverse biased.

105. (a) : The phase difference between output voltage and input signal voltage in common base transistor or circuit is zero.

106. (d) : Radiowaves of constant amplitude can be produced by using oscillator with proper feedback.

107. (a)

108. (a) : Distance between nearest atoms in body centred cubic lattice (bcc),  $d = \frac{\sqrt{3}}{2} a$   
Given  $d = 3.7 \text{ \AA}$ ,  $a = \frac{3.7 \times 2}{\sqrt{3}} \approx 4.3 \text{ \AA}$

109. (b) : The atomic radius in a f.c.c. crystal is  $\frac{a}{2\sqrt{2}}$

where  $a$  is the length of the edge of the crystal.

$$\therefore \text{Atomic radius} = \frac{3.6 \text{ \AA}}{2\sqrt{2}} = 1.27 \text{ \AA}$$

110. (c) : In a cubic crystal structure  
 $a = b = c$ ,  $\alpha = \beta = \gamma = 90^\circ$ .

111. (b) : Lattice constant for (f.c.c.)

$$= a = \text{interatomic spacing} \times \sqrt{2} = 3.59 \text{ \AA}$$

112. (c) : In body-centred cubic (b.c.c.) lattice there are eight atoms at the corners of the cube and one at the centre as shown in the figure.

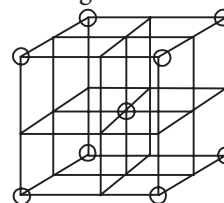

b.c.c. structure

Therefore number of atom per unit cell

$$= \frac{1}{8} \times 8 + 1 = 2$$

113. (b)

114. (c) :  $a = 4.225 \text{ \AA}$

For bcc cubic cell,  $4r = \sqrt{3} \times a$

$$\text{Therefore } 2r = \frac{\sqrt{3} \times a}{2} = \frac{1.732 \times 4.225}{2} = 3.66 \text{ \AA}$$

115. (b) : Diamond is very hard due to large cohesive energy.

116. (c) : van der Waals bonding is the weakest bonding in solids.

